

**Cassina**

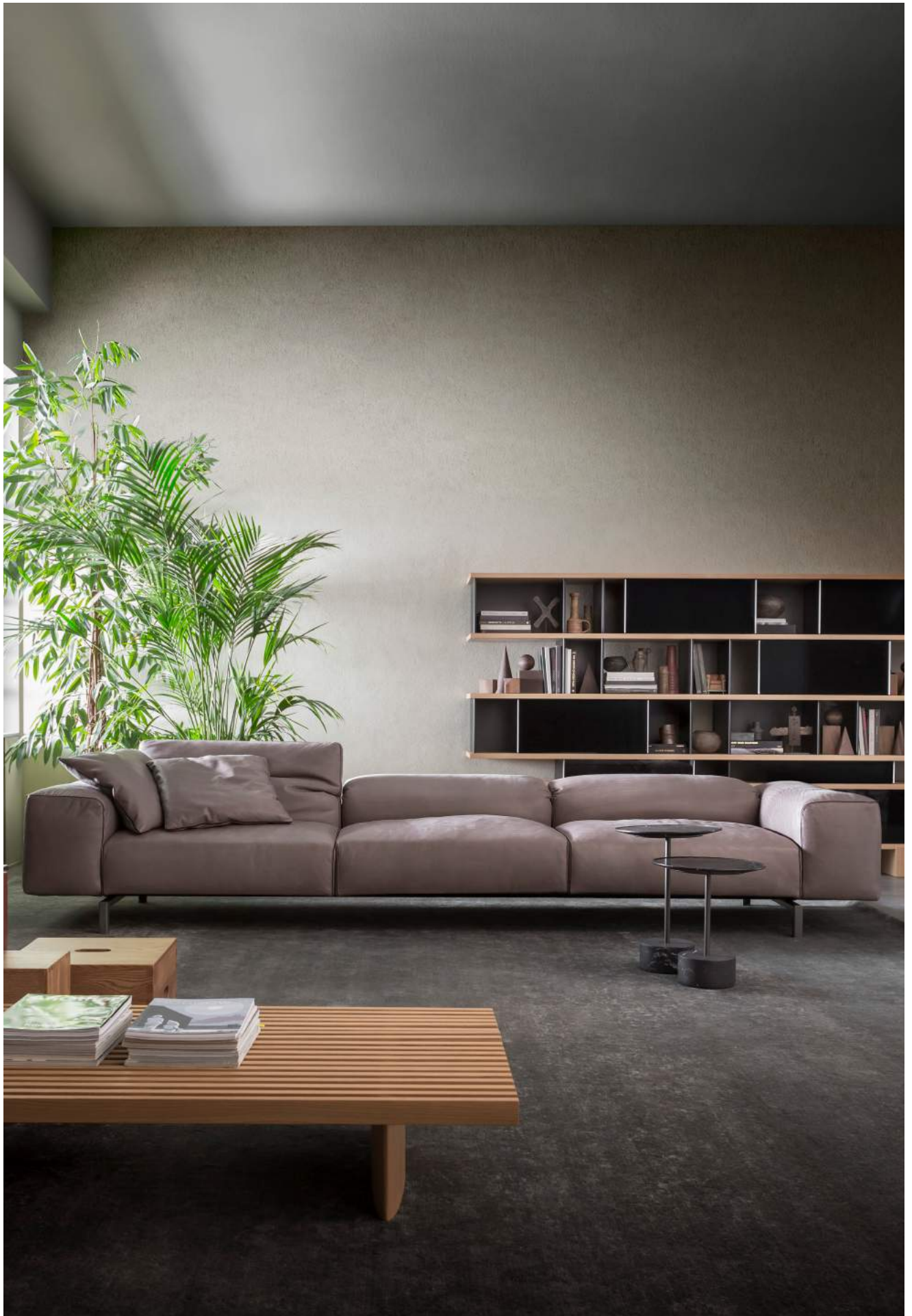

**204 Scighera**

**Piero Lissoni**



## Scighera

## Collezione Cassina iContemporanei



### designer

Piero Lissoni

### progetto / design entwurf / projet

2015

### produzione / production produktion / production

2015

### ITA

Architetto, art director, designer, apre nel 1986, con Nicoletta Canesi, lo studio Lissoni Associati e inizia collaborazioni che proseguono fino ad oggi con alcune delle migliori aziende di design italiane e internazionali. Lo studio si occupa dei diversi aspetti e sfaccettature del progetto.

Il lavoro dello studio Lissoni Associati comprende progetti d'architettura, di disegno industriale e di grafica, dall'arredamento agli accessori, dalle cucine ai bagni, dall'illuminazione alla corporate identity.

### ENG

Architect, art director, designer, Piero Lissoni, together with Nicoletta Canesi, opens the studio Lissoni Associati in 1986. He begins collaborating as designer and Art Director with some of the best Italian and international furniture manufacturers. The work of the studio embraces architecture, graphics and industrial design, with projects ranging from furniture, accessories, kitchens, bathroom and lighting fixtures to corporate identity.

### DEU

Architekt, künstlerischer Leiter und Designer. Zusammen mit Nicoletta Canesi eröffnet Piero Lissoni im Jahr 1986 das Studio Lissoni Associati. Er beginnt eine Zusammenarbeit als Designer und künstlerischer Leiter mit einigen der besten italienischen und internationalen Möbelhersteller. Zur Arbeit des Studios gehören die Bereiche Architektur, Grafik und Industriedesign mit Projekten von Möbeln, Accessoires, Küchen, Badezimmer und Leuchten bis hin zu Corporate Identity.

### FRA

Architecte, art director, designer, il ouvre en 1986 avec Nicoletta Canesi le cabinet Lissoni Associati et commence des collaborations qui continuent à ce jour avec certaines des meilleures entreprises du design italien et international. L'activité du cabinet est orientée aux différents aspects et détails du projet et comprend des projets d'architecture, dessin industriel et graphique, allant de l'ameublement aux accessoires, des cuisines aux salles de bains, de l'éclairage à la corporate identity.

### descrizione

Sistema di sedute composto da:

- divani a due o a tre posti, con braccioli stretti (25 cm) oppure larghi (34 cm)
- elementi componibili angolari
- terminali singoli o a due o tre posti (lato sinistro o destro)
- chaise longue componibili (lato sinistro o destro)
- cuscini opzionali
- pouf quadrato 90x90 h. 38 cm.

Le sedute hanno poggiatesta ribaltabile: il meccanismo di movimento consente differenti posizioni per un ottimale livello di comfort.

Richiuso, il poggiatesta rimane a filo bracciolo, enfatizzando così la linearità del design minimale.

Di particolare pregio è la cucitura, con profilo grosgrain, disponibile in 4 varianti di colori: beige, tabacco, caffè, grigio.

- Struttura di seduta con cinghie elastiche.
- Cuscini di seduta, schienali e braccioli in poliuretano espanso a densità differenziata con imbottitura in piuma.
- Rivestimento amovibile disponibile in tessuto o pelle.
- Basamento in metallo lucido oppure verniciato antracite opaco o marrone castagno opaco.

Il sistema è completato da una serie di tavolini, di forma quadrata, ovale o rettangolare, con piani in marmo bianco di Carrara o nero Marquìña oppure in vetro colore rosso mattone oppure caffè.

### description

Pronounced she-gera, this seating system includes:

- two- and three seater sofas with narrow (25 cm - 9.8") or large armrests (34 cm - 13.4")
- modular corner units
- single or two- or three seater end units (left or right side),
- modular chaise lounge (left or right side)
- optional cushions
- square ottoman 90x90 h. 39 cm (35.4"x35.4" h. 15")

The seats have foldable headrest, whose movable mechanism provides for different positions to ensure an excellent level of comfort.

When closed the headrest lies flush with the armrest, thus emphasizing the linear nature of the minimalist design.

The exceptional quality stitching with grosgrain profile is available in four colour options: beige, tobacco, coffee and grey.

- Seat frame with elastic straps.
- Seat cushions, backrest and armrests are in differentiated density polyurethane foam padded in feather.
- Removable upholstery available in fabric or leather.
- Base in gloss metal or matt enamelled metal in the colours: anthracite grey or chestnut brown.

The collection is completed with a range of square, oval or rectangular side tables with white Carrara or black Marquìña marble or glass tops in the colours brick red or coffee.

### beschreibung

Das Sitzmöbel-Programm umfasst:

- zwei- oder dreisitzige Sofas mit großflächigen (34 cm) oder schmalen (25 cm) Armlehnen
- Anbau-Eckelemente
- Endmodule ein- zwei- oder dreisitzig (links oder rechts)
- Anbau-Chaiselongues (links oder rechts)
- frei wählbare Kissen
- quadratischer Hocker 90x90 H. 38 cm.

Die Sitzmöbel haben Klapp-Kopfstützen, der Regelmehanismus ermöglicht verschiedene Positionen für den optimalen Sitzkomfort. Bei geschlossener Kopfstütze befindet sich letztere auf gleicher Ebene mit der Armlehne und betont das lineare, minimale Design. Besonders elegant sind die Grosgrain-Nähte, die in den vier Farbvarianten beige, tabak, kaffee und grau erhältlich sind.

- Gestell mit Elastikgurten.
- Sitzkissen, Rückenlehnen und Armlehnen aus Polyurethanschaumstoff mit differenzierter Dichte und Daunepolsterung.
- Abziehbarer Stoff- oder Lederbezug.
- Metallstützgestell glänzend oder matt lackiert in den Farben: anthrazitgrau oder kastanienbraun.

Das Sitzmöbel-Programm wird durch eine Serie quadratischer, ovaler oder rechteckiger Tische mit weiß Carrara oder schwarz Marquìña Marmor oder Glasplatte in den Farben ziegelrot oder kaffee komplettiert.

### description

Le système de sièges se compose de:

- canapés à deux ou trois places avec accoudoirs larges (34 cm) ou bien étroits (25 cm)
- éléments modulables d'angle
- terminaux, à une, deux ou trois places (côté gauche ou droit)
- chaises-longues modulables (côté gauche ou droit)
- coussins optionnels
- pouf carré 90x90 h. 38 cm.

Les sièges ont appui-tête inclinable, le mécanisme de mouvement permet des positions différentes, pour garantir un niveau de confort optimal.

Refermé, l'appui-tête reste au fil de l'accoudoir, soulignant ainsi la linéarité du design minimaliste.

La couture, au profil gros grain, est particulièrement remarquable et est disponible en 4 variantes de couleurs: beige, tabac, café, gris.

- Structure d'assise avec des sangles élastiques.
- Coussins d'assise, des dossiers et des accoudoirs en mousse de polyuréthane à densité différenciée, avec rembourrage en plume.
- Housse amovible disponible en tissu ou en cuir.
- Piétement en métal brillant ou bien laqué en couleur anthracite ou marron châtaignier.

Le système est complété par une série de petites tables, de forme carrée, ovale ou rectangulaire, avec des plateaux en marbre Carrara blanc ou noir Marquìña ou en verre couleurs rouge brique ou bien café.















**dimensioni / dimensions  
maße / dimensions**

204 04

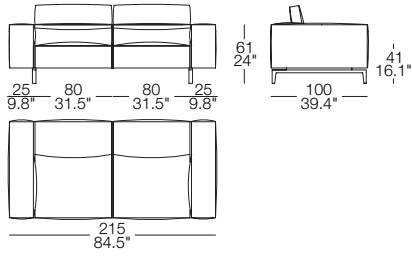

204 05

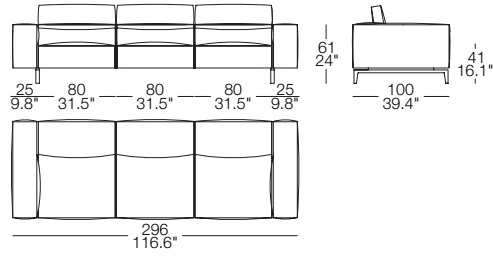

204 02

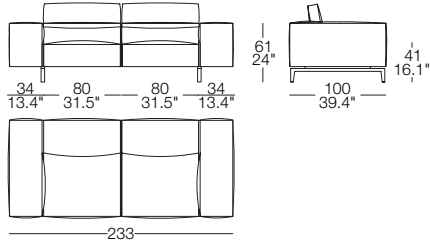

204 41

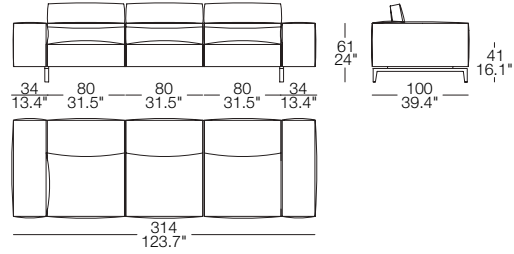

204 03

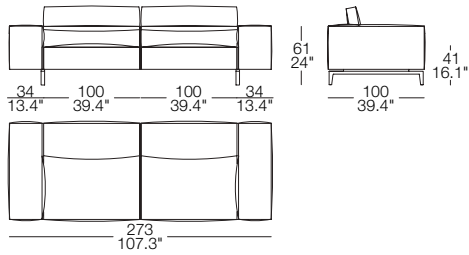

204 42

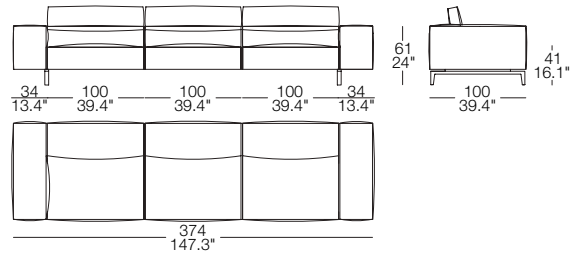

204 43

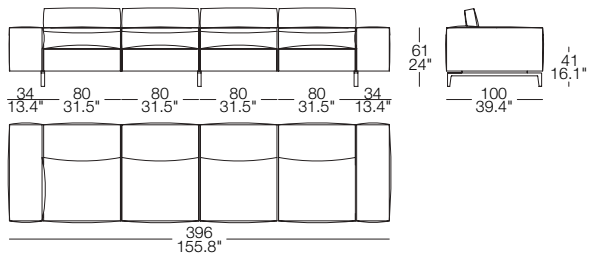

204 44

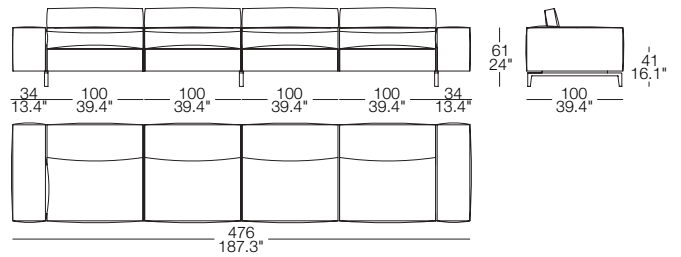

204 09

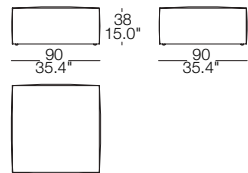

204 90

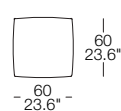

204 91

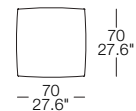



204 21

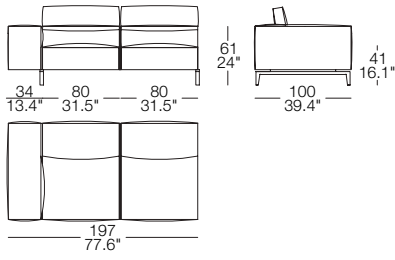

204 22

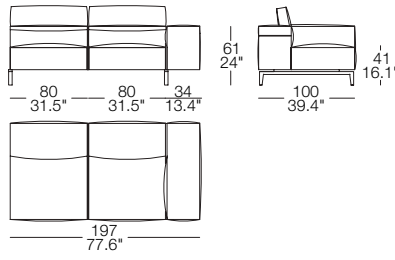

204 23

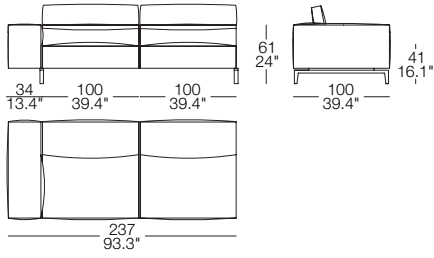

204 24

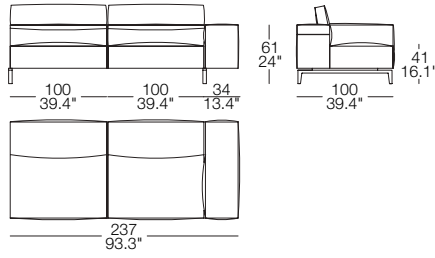

204 31

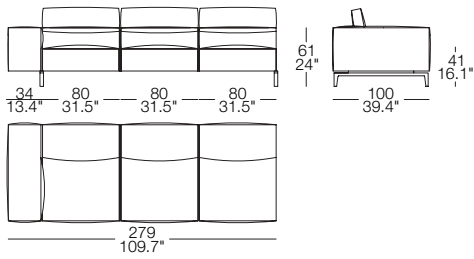

204 32

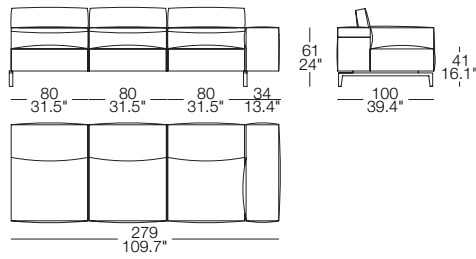

204 33

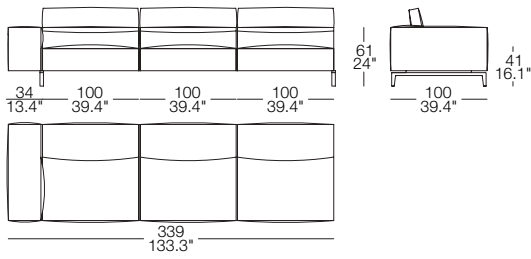

204 34

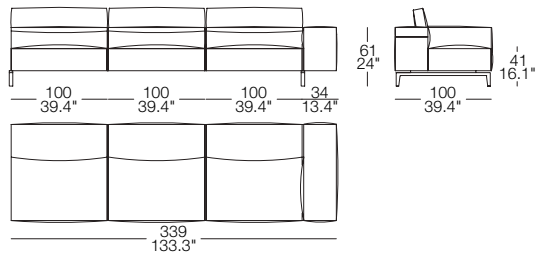

204 18

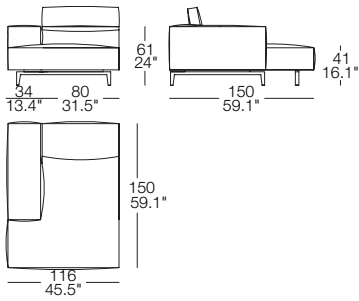

204 19

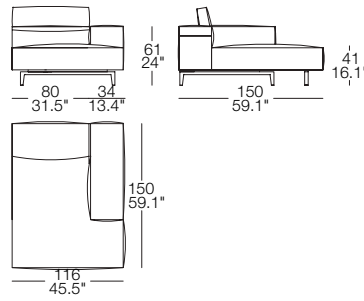

composizioni suggerite / recommended compositions  
empfohlene kompositionen / compositions conseillées

204 18 + 204 22

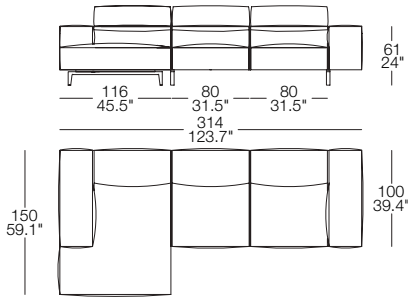

204 18 + 204 32

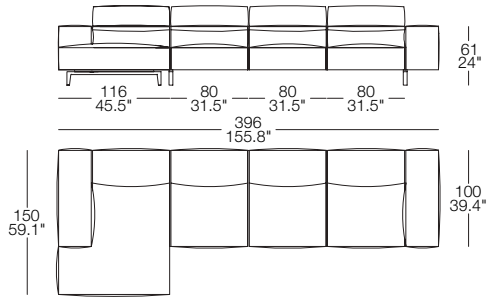

204 41 + 204 21

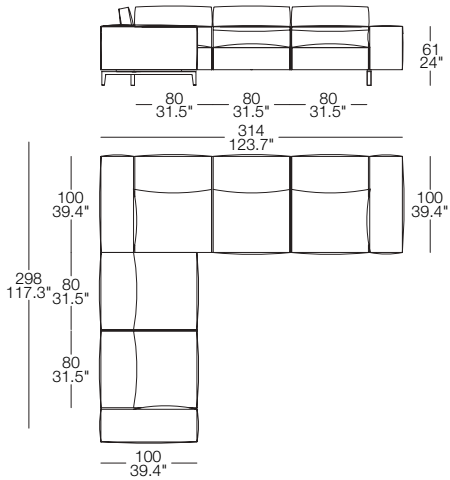

204 42 + 204 21

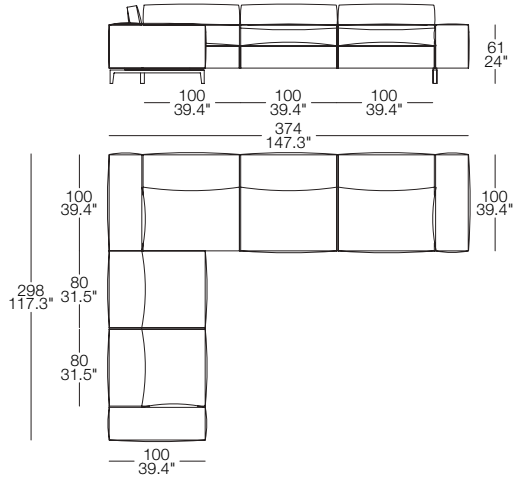

204 42 + 204 23

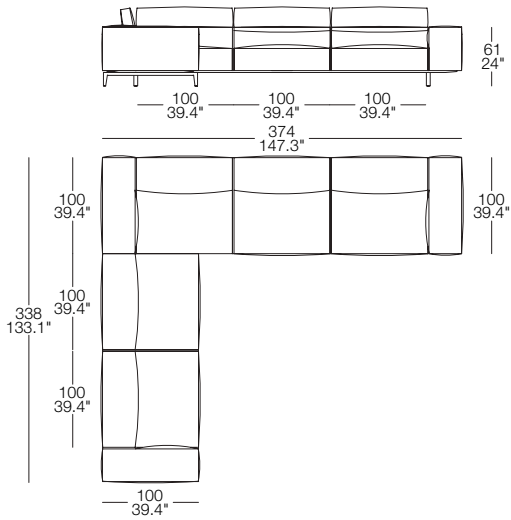

204 44 + 204 33

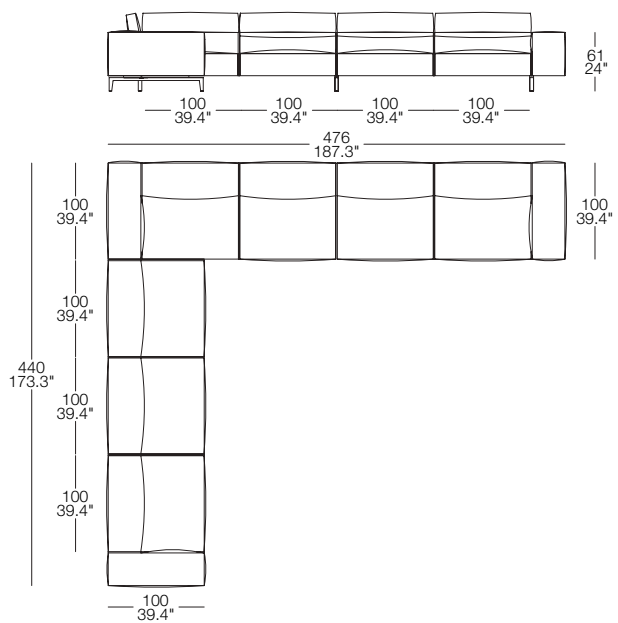



**finiture / finishes  
ausführungen / finitions**

**base/  
base /  
basis /  
base**



metallo lucido /  
gloss metal /  
metallstützgestell glänzend /  
métal brillant



antracite opaco /  
matte anthracite grey /  
anthrazitgrau /  
anthracite mat



marrone castagno opaco /  
matte chestnut brown /  
kastanienbraun matt /  
marron châtaignier mat

**rivestimenti consigliati /  
suggested upholstery /  
empfohlene bezüge /  
revêtements conseillés**



Morandi 1\_Diablo 13F760



Everest 2\_Pamir 13O094



Everest 2\_Annapurna 13F364



pelle naturale 13Z306 /  
13Z306 natural leather /  
leder natur 13Z306 /  
cuir naturel 13Z306



### certificazioni aziendali

Qualità  
UNI EN ISO 9001  
Sistema ambientale  
UNI EN ISO 14001  
Salute e sicurezza nei luoghi di lavoro  
BS OHSAS 18001

### company certifications

Quality management  
UNI EN ISO 9001  
Environmental management  
UNI EN ISO 14001  
Health and safety in the workplace  
BS OHSAS 18001

### unternehmenszertifizierungen

Qualitätssystem  
UNI EN ISO 9001  
Umwelt-Managementsystem  
UNI EN ISO 14001  
Arbeits- und Gesundheitsschutz-  
Managementsystem  
BS OHSAS 18001

### certifications de l'entreprise

Qualité  
UNI EN ISO 9001  
Système environnemental  
UNI EN ISO 14001  
Santé et sécurité sur les lieux de travail  
BS OHSAS 18001

### espansi senza CFC

Gli espansi sono prodotti senza l'utilizzo di CFC.

### CFC free foams

The foams are produced without the use of CFC.

### FCKW-freie schaumstoffe

Die Schaumstoffe werden ohne Verwendung von FCKW hergestellt.

### mousses sans CFC

Les mousses sont produites sans CFC.



# Cassina

**Cassina S.p.A.**  
via L. Busnelli, 1  
I - 20821 Meda (MB)  
Tel. +39 0362372.1  
Fax +39 0362342246  
[www.cassina.com](http://www.cassina.com)  
[info@cassina.it](mailto:info@cassina.it)

