

Table tube d'avion, section ovoïde

Table with semigloss grey, light blue, green, mud, ivory or black enamelled steel base.

Base has four supporting points with steel threaded shanks, permitting height adjustment up to 50 mm. (1.97")

Tops:

- crystal or textured glass (size 225x85 cm. – 88.6"x33.5")
- natural oak, black-stained oak or American walnut (size 170x75 cm. – 66.9"x29.5").

Other combinations:

- black enamelled steel base with tops, size 225x85 cm. . – 88.6"x33.5", in black Marquina marble, white Carrara marble or black soft touch material;
- ivory enamelled steel base with white Carrara marble top.

Feet: black plastic material with felts.

The base of this table was designed in 1928 using the ovoidal profiles adopted in aviation to maintain separate the wings of biplanes. The version presented at the Salon d'Automne in 1929 had a rose coloured printed glass top and a green base; later, Charlotte Perriand developed, among other versions, also a model with a blue top and an ivory coloured base.

Gallery





Avorio



Azzurro



Verde



Fango



Grigio



Nero

Dimensions

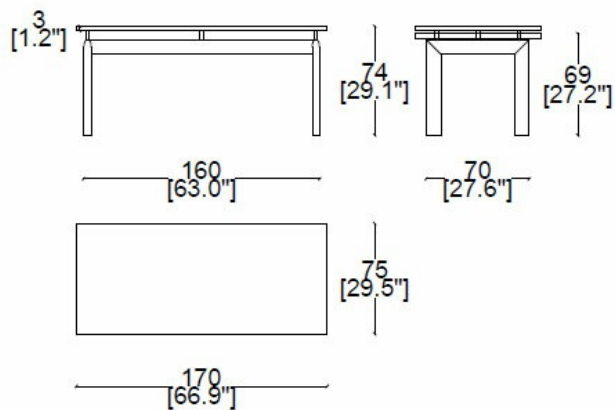

Authenticity

All the models in the Cassina collection, by merit of their artistic content and particular creative character, are protected by copyright, a legal institution that is universally recognised and safeguarded; legal protection is assured for the whole life-span of the author and for 70 years after his/her death (or the death of the last surviving co-author).

Designer



Le Corbusier, Pierre Jeanneret, Charlotte Perriand

In 1922, Le Corbusier began working in the new rue de Sèvres, Paris, atelier with his cousin Pierre Jeanneret with whom he shared research projects and design criteria in a profound and life-long professional relationship.

In October 1927, the pair decided to draw on the contribution of a young architect who had already begun to establish a reputation on the architectural scene of the time: Charlotte Perriand.

Their collaboration lasted through to 1937 and was extremely fruitful, especially in the field of furniture design. The partnership was highly significant, both in terms of the cultural weight of their achievements and their professional successes.

It was together with Charlotte Perriand that the pair tackled the innovative project for "l'équipement d'intérieur de l'habitation".

The resulting designs were of great intellectual value and considerable commercial success.

Thanks to Cassina's ongoing production, there is continued interest in the conceptual contents of the work and the level of quality attained.

Due to these characteristics, each item in the collection is eagerly awaited.

<http://www.fondationlecorbusier.fr/>